

LP2995 Evaluation Board

National Semiconductor
Application Note 1241
Chance Dunlap
August 2002



Introduction

The LP2995 evaluation board is designed to provide the design engineer with a fully functional prototype system in which to evaluate the LP2995 in both a static environment and with a complete memory system. There are two versions of the board, while identical in functionality they differ in the package implemented, either an SO-8 or LLP-16 LP2995 is

used. This application note contains information regarding the evaluation board. For more information regarding the LP2995 please refer to the datasheet.

Schematic

The following schematic was used to create the layout.

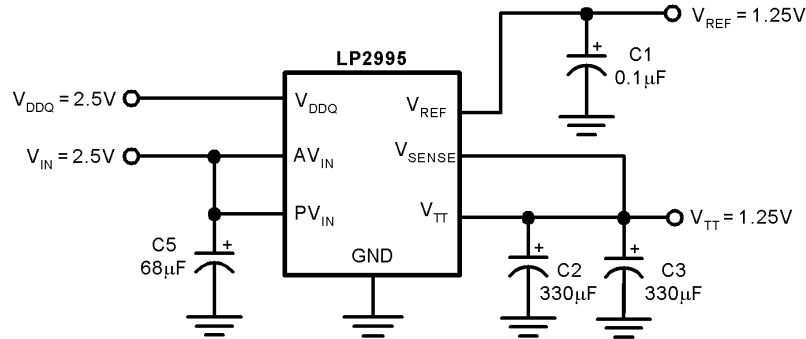

20049101

FIGURE 1. Schematic

TABLE 1. Bill Of Materials

Name	Value	Description	Manufacturer	Model Number
U1		LP2995 DDR Linear Regulator	National Semiconductor	LP2995M or LP2995LQ
C1	0.1µF	1206 Ceramic Capacitor X7R 25V	Vishay Vitrammon	VJ1206Y104KXXAT
C2	330µF	6.3V Electrolytic Radial FC Series	Panasonic	EEU-FC0J331S
C3	330µF	6.3V Electrolytic Radial FC Series	Panasonic	EEU-FC0J331S
C4		Not Connected		
C5	68µF	6.3V Electrolytic Radial FC series	Panasonic	EEU-FC0J680

Application

The LP2995 evaluation board can be used immediately in either a static test environment to check functionality or in a memory termination scheme on a motherboard. In either implementation the following steps should be taken to ensure correct operation.

1. Connect leads from the evaluation board. The board layout has been designed to allow banana jack sockets to be directly soldered.
2. V_{IN} should be connected to a 2.5V power supply. This pad connects both the AV_{IN} and PV_{IN} pins of the LP2995.
3. Two GND pads have been provided for ease of use. Either is sufficient for grounding of the board.
4. The V_{DDQ} input provides the internal divide by two reference voltage. Both V_{REF} and V_{TT} will track this internal voltage, nominally a 2.5V will be applied.
5. The V_{REFOUT} pad is the output for the V_{REF} from the LP2995 after being bypassed by a ceramic capacitor. This can be connected either to a multimeter for confirmation or directly to the memory controller and DIMMS.
6. The remaining two pads are for the force and sense leads of the V_{TT} output. These should be connected directly to the termination plane or a multimeter if interested in verification. The output will be regulated where the V_{SENSE} leads connect to the V_{TT} leads permitting the connection to a motherboard without suffering from large resistance drops.

Performance

The following series of scope plots shows the performance of the LP2995 evaluation board when it is subjected to various load tests. On each of the six scope plots there are two traces. The upper trace is the V_{TT} output voltage that has been AC coupled with a scale of 20mV per division. The

lower trace is the output current with a scale of 500mA per division. All the load transients begin from an initial condition of zero current and show magnitude. Please refer to the title to determine whether the current flow is into (sinking) or out of (sourcing) the V_{TT} pin. The time scale for all the plots is 2mS per division.

0.5A Load Transient (Sourcing)

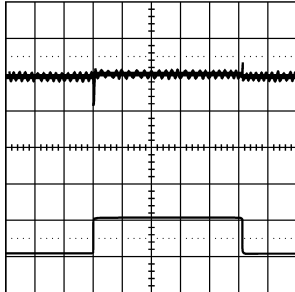

20049107

1A Load Transient (Sourcing)

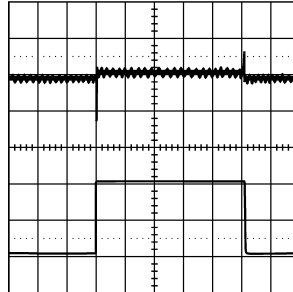

20049106

1.5A Load Transient (Sourcing)

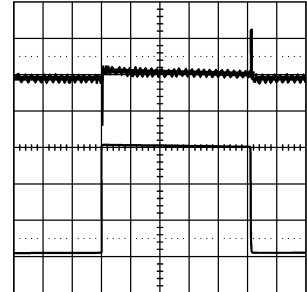

20049109

0.5A Load Transient (Sinking)

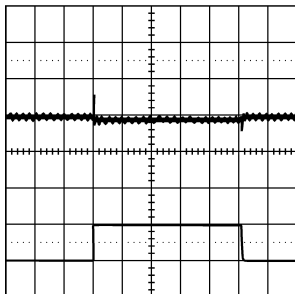

20049111

1A Load Transient (Sinking)

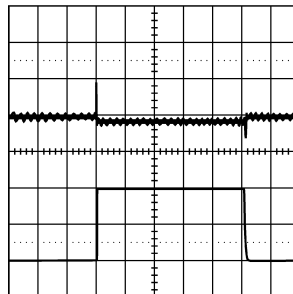

20049110

1.5A Load Transient (Sinking)

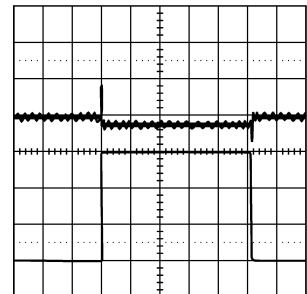

20049108

The LP2995 has been designed to accommodate several different capacitor options to allow the designer to optimize the solution for the specific application. For most desktop systems large aluminum electrolytic capacitors will be used for their low cost. However, in height limited situations such

as laptops fewer high performance capacitors might be implemented such as specialty polymers. The table below lists some of the capacitors that can be used and a vendor that offers that product line.

TABLE 2.

Capacitor Series	Vendor	Vendor Phone Number
Oscon	Vishay	(207) 324-4140
SP	Panasonic	(714) 373-7857
MLCC	Taiyo Yuden	(800)-348-2496
Aluminum	Panasonic	(714) 373-7857

Board Layout

LLP Top Side

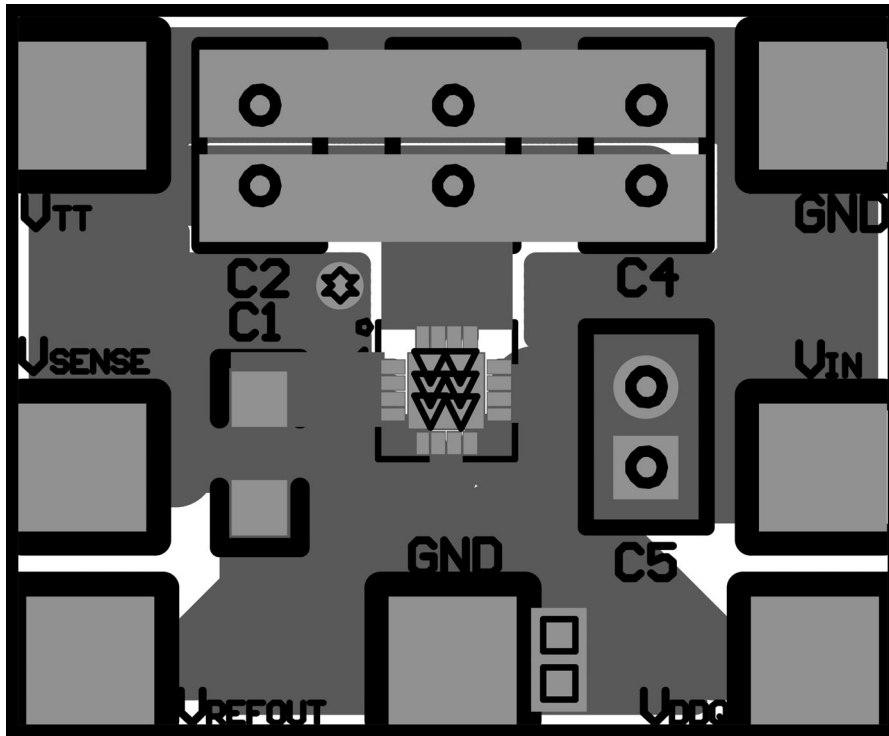

20049103

LLP Bottom Side

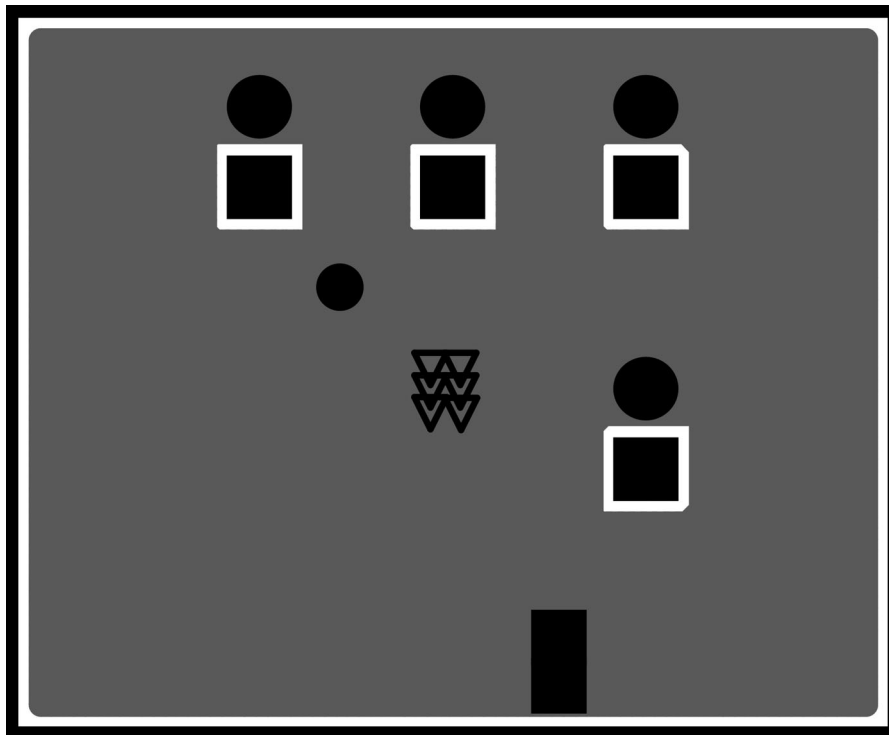

20049102

Board Layout (Continued)

SO-8 Top Side

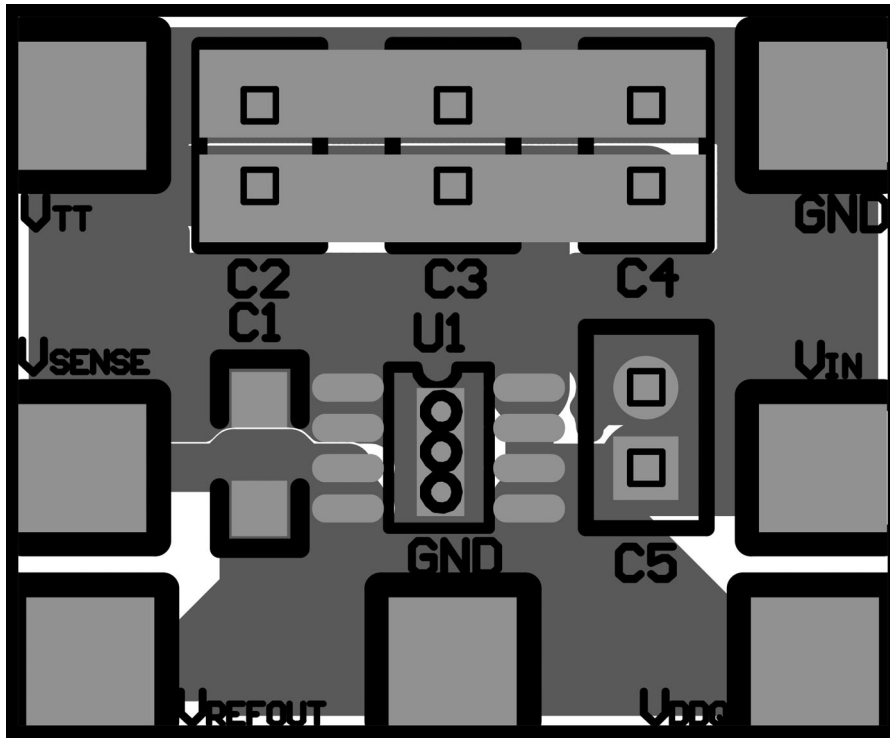

20049104

SO-8 Bottom Side

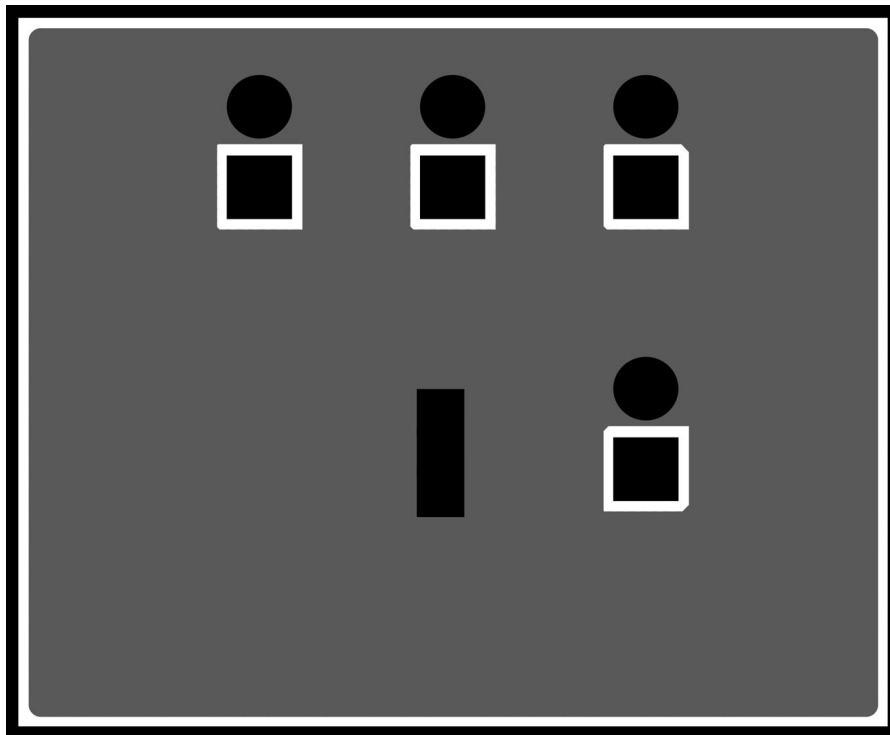

20049105

Board Layout (Continued)

TABLE 3.

Information	SO-8 Board	LLP-16 Board
Board Material	FR4	FR4
Size	0.9 x 1.1 inches	0.9 x 1.1 inches
Board Thickness	0.062 inch	0.062 inch
Layers	2	2
Copper Thickness	1 oz	1 oz
Plating	HASL	HASL
Thermal Vias	3	6
Thermal Vias Size	25 mil	10 mil
Board Thickness	0.062 inch	0.062 inch

LIFE SUPPORT POLICY

NATIONAL'S PRODUCTS ARE NOT AUTHORIZED FOR USE AS CRITICAL COMPONENTS IN LIFE SUPPORT DEVICES OR SYSTEMS WITHOUT THE EXPRESS WRITTEN APPROVAL OF THE PRESIDENT AND GENERAL COUNSEL OF NATIONAL SEMICONDUCTOR CORPORATION. As used herein:

1. Life support devices or systems are devices or systems which, (a) are intended for surgical implant into the body, or (b) support or sustain life, and whose failure to perform when properly used in accordance with instructions for use provided in the labeling, can be reasonably expected to result in a significant injury to the user.
2. A critical component is any component of a life support device or system whose failure to perform can be reasonably expected to cause the failure of the life support device or system, or to affect its safety or effectiveness.



National Semiconductor Corporation
Americas
Email: support@nsc.com

www.national.com

National Semiconductor Europe

Fax: +49 (0) 180-530 85 86
Email: europe.support@nsc.com
Deutsch Tel: +49 (0) 69 9508 6208
English Tel: +44 (0) 870 24 0 2171
Français Tel: +33 (0) 1 41 91 8790

National Semiconductor Asia Pacific Customer Response Group

Tel: 65-2544466
Fax: 65-2504466
Email: ap.support@nsc.com

National Semiconductor Japan Ltd.

Tel: 81-3-5639-7560
Fax: 81-3-5639-7507